

If you have questions or comments, contact us.  
Pour toute question ou tout commentaire, nous contacter.

1-800-4-DEWALT • www.dewalt.com

INSTRUCTIVO DE OPERACIÓN. CENTROS DE SERVICIO  
Y PÓLIZA DE GARANTÍA. ADVERTENCIA: LEASE ESTE  
INSTRUCTIVO ANTES DE USAR EL PRODUCTO.

INSTRUCTION MANUAL  
GUIDE D'UTILISATION  
MANUAL DE INSTRUCCIONES

# DEWALT®

D21002, D21007, D21008, D21009, DWD110, DWD112, DWD115  
3/8" (10 mm) V.S.R. Drill  
Perceuse de 10 mm (3/8 po) à régulateur de vitesse et inverseur  
de marche  
Taladro de 10 mm (3/8 pulg.) V.V.R.

DEWALT Industrial Tool Co., 701 East Joppa Road, Baltimore, MD 21286  
(AUG07) Form No. 655014-00 D21002, D21007, D21008, D21009, DWD110, DWD112, DWD115  
Copyright © 2002, 2004, 2007 DEWALT

The following are trademarks for one or more DEWALT power tools: the yellow and black color scheme; the "D" shaped air intake grill; the array of pyramids on the handgrip; the kit box configuration; and the array of lozenge-shaped humps on the surface of the tool.

### Definitions: Safety Guidelines

The definitions below describe the level of severity for each signal word. Please read the manual and pay attention to these symbols.

**⚠ DANGER:** Indicates an imminently hazardous situation which, if not avoided, will result in death or serious injury.

**⚠ WARNING:** Indicates a potentially hazardous situation which, if not avoided, could result in death or serious injury.

**⚠ CAUTION:** Indicates a potentially hazardous situation which, if not avoided, may result in minor or moderate injury.

**CAUTION:** Used without the safety alert symbol indicates a potentially hazardous situation which, if not avoided, may result in property damage.

IF YOU HAVE ANY QUESTIONS OR COMMENTS ABOUT THIS OR ANY DEWALT TOOL, CALL US TOLL FREE AT: 1-800-4-DEWALT (1-800-433-9258)

### General Safety Rules - For All Tools

**⚠ WARNING!** Read all instructions. Failure to follow all instructions listed below may result in electric shock, fire and/or serious injury. The term "power tool" in all of the warnings listed below refers to your mains-operated (corded) power tool or battery-operated (cordless) power tool.

### SAVE THESE INSTRUCTIONS

#### 1) WORK AREA SAFETY

- Keep work area clean and well lit. Cluttered or dark areas invite accidents.
- Do not operate power tools in explosive atmospheres, such as in the presence of flammable liquids, gases or dust. Power tools create sparks which may ignite the dust or fumes.
- Keep children and bystanders away while operating a power tool. Distractions can cause you to lose control.

#### 2) ELECTRICAL SAFETY

- Power tool plugs must match the outlet. Never modify the plug in any way. Do not use any adapter plugs with earthed (grounded) power tools. Unmodified plugs and matching outlets will reduce risk of electric shock
- Avoid body contact with earthed or grounded surfaces such as pipes, radiators, ranges and refrigerators. There is an increased risk of electric shock if your body is earthed or grounded.
- Do not expose power tools to rain or wet conditions. Water entering a power tool will increase the risk of electric shock
- Do not abuse the cord. Never use the cord for carrying, pulling or unplugging the power tool. Keep cord away from heat, oil, sharp edges or moving parts. Damaged or entangled cords increase the risk of electric shock. Replace or repair damaged cords. Make sure your extension cord is in good condition. Use only 3-wire extension cords that have 3-prong grounding-type plugs and 3-pole receptacles that accept the tool's plug.
- When operating a power tool outdoors, use an extension cord suitable for outdoor use. Use of a cord suitable for outdoor use reduces the risk of electric shock. When using an extension cord, be sure to use one heavy enough to carry the current your product will draw. An undersized cord will cause a drop in line voltage resulting in loss of power and overheating. The following table shows the correct size to use depending on cord length and nameplate ampere rating. If in doubt, use the next heavier gauge. The smaller the gauge number, the heavier the cord.

Ampere Rating		Minimum Gauge for Cord Sets				
		Volts	Total Length of Cord in Feet (meters)			
More Than	Not More Than	120V	25 (7.6)	50 (15.2)	100 (30.5)	150 (45.7)
		240V	50 (15.2)	100 (30.5)	200 (61.0)	300 (91.4)
		AWG				
0	6		18	16	16	14
6	10		18	16	14	12
10	12		16	16	14	12
12	16		14	12	Not Recommended	

#### 3) PERSONAL SAFETY

- Stay alert, watch what you are doing and use common sense when operating a power tool. Do not use a power tool while you are tired or under the influence of drugs, alcohol or medication. A moment of inattention while operating power tools may result in serious personal injury.
- Use safety equipment. Always wear eye protection. Safety equipment such as dust mask, non-skid safety shoes, hard hat, or hearing protection used for appropriate conditions will reduce personal injuries.
- Avoid accidental starting. Ensure the switch is in the off-position before plugging in. Carrying power tools with your finger on the switch or plugging in power tools that have the switch on invites accidents.
- Remove any adjusting key or wrench before turning the power tool on. A wrench or a key left attached to a rotating part of the power tool may result in personal injury.
- Do not overreach. Keep proper footing and balance at all times. This enables better control of the power tool in unexpected situations.
- Dress properly. Do not wear loose clothing or jewellery. Keep your hair, clothing and gloves away from moving parts. Loose clothes, jewellery or long hair can be caught in moving parts. Air vents often cover moving parts and should also be avoided.
- If devices are provided for the connection of dust extraction and collection facilities, ensure these are connected and properly used. Use of these devices can reduce dust-related hazards.

#### 4) POWER TOOL USE AND CARE

- Do not force the power tool. Use the correct power tool for your application. The correct power tool will do the job better and safer at the rate for which it was designed.
- Do not use the power tool if the switch does not turn it on and off. Any power tool that cannot be controlled with the switch is dangerous and must be repaired.
- Disconnect the plug from the power source and/or the battery pack from the power tool before making any adjustments, changing accessories, or storing power tools. Such preventive safety measures reduce the risk of starting the power tool accidentally.
- Store idle power tools out of the reach of children and do not allow persons unfamiliar with the power tool or these instructions to operate the power tool. Power tools are dangerous in the hands of untrained users.
- Maintain power tools. Check for misalignment or binding of moving parts, breakage of parts and any other condition that may affect the power tool's operation. If damaged, have the power tool repaired before use. Many accidents are caused by poorly maintained power tools.
- Keep cutting tools sharp and clean. Properly maintained cutting tools with sharp cutting edges are less likely to bind and are easier to control.
- Use the power tool, accessories and tool bits etc., in accordance with these instructions and in the manner intended for the particular type of power tool, taking into account the working conditions and the work to be performed. Use of the power tool for operations different from those intended could result in a hazardous situation.

#### 5) SERVICE

- Have your power tool serviced by a qualified repair person using only identical replacement parts. This will ensure that the safety of the power tool is maintained.

### Additional Specific Safety Instructions for Drills

- Hold power tools by insulated gripping surfaces when performing an operation where the cutting tool may contact hidden wiring or its own cord. Contact with a "live" wire will make exposed metal parts of the tool "live" and shock the operator.
- Use clamps or other practical way to secure and support the workpiece to a stable platform. Holding the work by hand or against your body is unstable and may lead to loss of control.
- Keep handles dry, clean, free from oil and grease. It is recommended to use rubber gloves. This will enable better control of the tool.

**⚠ WARNING: ALWAYS** use safety glasses. Everyday eyeglasses are NOT safety glasses. Also use face or dust mask if cutting operation is dusty. ALWAYS WEAR CERTIFIED SAFETY EQUIPMENT:

- ANSI Z87.1 eye protection (CAN/CSA Z94.3),
- ANSI S12.6 (S3.19) hearing protection,
- NIOSH/OSHA/MSHA respiratory protection.

**⚠ WARNING: Always use eye protection.** All users and bystanders must wear eye protection that conforms to ANSI Z87.1.

**⚠ WARNING:** Some dust created by power sanding, sawing, grinding, drilling, and other construction activities contains chemicals known to cause cancer, birth defects, or other reproductive harm. Some examples of these chemicals are:

- lead from lead-based paints,
- crystalline silica from bricks and cement and other masonry products, and
- arsenic and chromium from chemically-treated lumber (CCA).

Your risk from these exposures varies, depending on how often you do this type of work. To reduce your exposure to these chemicals: work in a well ventilated area, and work with approved safety equipment, such as those dust masks that are specially designed to filter out microscopic particles.

- Avoid prolonged contact with dust from power sanding, sawing, grinding, drilling, and other construction activities. Wear protective clothing and wash exposed areas with soap and water. Allowing dust to get into your mouth, eyes, or lay on the skin may promote absorption of harmful chemicals.

**⚠ WARNING:** Use of this tool can generate and/or disburse dust, which may cause serious and permanent respiratory or other injury. Always use NIOSH/OSHA approved respiratory protection appropriate for the dust exposure. Direct particles away from face and body.

- The label on your tool may include the following symbols. The symbols and their definitions are as follows:

V..... volts	A..... amperes
Hz..... hertz	W..... watts
min ..... minutes	~ ..... alternating current
== ..... direct current	n <sub>o</sub> ..... no load speed
⚠ ..... Class I Construction (grounded)	⊕ ..... earthing terminal
⊠ ..... Class II Construction (double insulated)	⚠ ..... safety alert symbol
BPM..... beats per minute	.../min..... revolutions or reciprocation per minute

### SAVE THESE INSTRUCTIONS

#### Motor

Be sure your power supply agrees with the nameplate marking. Voltage decrease of more than 10% will cause loss of power and overheating. DEWALT tools are factory tested; if this tool does not operate, check power supply.

### COMPONENTS (FIG. 1, 2, 3)

**⚠ WARNING:** Never modify the power tool or any part of it. Damage or personal injury could result.

- Trigger switch
- Reversing lever
- Bubble level
- Bubble level bulls-eye
- Keyless chuck  
Keyed chuck (not shown)

## INTENDED USE

The heavy-duty V.S.R. drills are designed for professional drilling at various work sites (i.e., construction sites). **DO NOT** use under wet conditions or in presence of flammable liquids or gases.

These heavy-duty V.S.R. drills are professional power tools. **DO NOT** let children come into contact with the tool. Supervision is required when inexperienced operators use this tool.

## Switches (Fig. 1)

To start the drill, depress the trigger switch; to stop the drill, release the trigger.

A variable speed trigger switch (A) permits speed control—the farther the trigger is depressed, the higher the speed of the drill.

**NOTE:** Use lower speeds for starting holes without a center punch, drilling in metal or plastics, driving screws or drilling ceramics. Higher speeds are better for drilling wood and composition boards and using abrasive and polishing accessories.

The reversing lever (B) is used for withdrawing bits from tight holes and removing screws. It is located above the trigger switch. To reverse the motor, release the trigger switch **FIRST** and then push the lever to the right. After any reversing operations, return lever to forward position.

## OPERATION

**⚠ WARNING: To reduce the risk of serious personal injury, turn tool off and disconnect tool from power source before making any adjustments or removing/installing attachments or accessories.**

### Drilling

**⚠ WARNING: To reduce the risk of personal injury, ALWAYS ensure workpiece is anchored or clamped firmly. If drilling thin material, use a wood "back-up" block to prevent damage to the material.**

1. Use sharp drill bits only. For WOOD, use twist drill bits, spade bits, power auger bits, or hole saws. For METAL, use steel twist drill bits or hole saws. For MASONRY, such as brick, cement, cinder block, etc., use carbide-tipped bits rated for percussion drilling.
2. Always apply pressure in a straight line with the bit. Use enough pressure to keep drill biting, but do not push hard enough to stall the motor or deflect the bit.
3. Hold tool firmly with both hands to control the twisting action of the drill.
4. **IF DRILL STALLS**, it is usually because it is being overloaded or improperly used. **RELEASE TRIGGER IMMEDIATELY**, remove drill bit from work, and determine cause of stalling. **DO NOT CLICK TRIGGER ON AND OFF IN AN ATTEMPT TO START A STALLED DRILL — THIS CAN DAMAGE THE DRILL.**
5. To minimize stalling or breaking through the material, reduce pressure on drill and ease the bit through the last fractional part of the hole.
6. Keep the motor running when pulling the bit back out of a drilled hole. This will help prevent jamming.
7. With variable speed drills there is no need to center punch the point to be drilled. Use a slow speed to start the hole and accelerate by squeezing the trigger harder when the hole is deep enough to drill without the bit skipping out.

### DRILLING IN METAL

Start drilling with slow speed and increase to full power while applying firm pressure on the tool. A smooth even flow of metal chips indicates the proper drilling rate. Use a cutting lubricant when drilling metals. The exceptions are cast iron and brass which should be drilled dry.

**NOTE:** Large [5/16" (8 mm) to 1/2" (13 mm)] holes in steel can be made easier if a pilot hole [5/32" (4 mm) to 3/16" (5 mm)] is drilled first.

### DRILLING IN WOOD

Start drilling with slow speed and increase to full power while applying firm pressure on the tool. Holes in wood can be made with the same twist drills used for metal. These bits may overheat unless pulled out frequently to clear chips from the flutes. Work that is apt to splinter should be backed up with a block of wood.

### DRILLING IN MASONRY

When drilling in masonry, use carbide-tipped bits rated for percussion drilling and be certain that the bits are sharp. Use a constant and firm force on the tool to drill most effectively. A smooth, even flow of dust indicates the proper drilling rate.

## Bubble Level – DWD110, DWD112, DWD115 (Fig. 2)

Your drill is equipped with a bubble level (C) that assists you in drilling level holes.

For horizontal drilling, tilt the drill up or down as required so that the bubble floats in the center of the parallel lines drawn on the glass. When the bubble is centered between the lines, the drill is level.

For vertical drilling, align the drill so that the bubble floats in the center of the bull's-eye, (D).

To assure accuracy, first place a level on your work piece and position it so that it is level. Then, when the drill reads level, the two will be aligned. (Any bubble level can only indicate level to the earth's surface).

**NOTE:** The fluid in the bubble level vial is mineral spirits. If the mineral spirits gets into your eyes, flush eyes with water. If irritation occurs, seek medical attention. If the vial fluid comes into contact with your skin, remove contaminated clothing and remove excess fluid. Rinse thoroughly with water followed by washing with soap and water. If irritation occurs, seek medical attention. If vial fluid is inhaled, immediately get fresh air. If difficulty breathing, seek medical attention.

## Keyless Chuck – D21007, D21008, D21009, DWD110, DWD115 (Fig. 3)

Your tool features a keyless chuck (E) for greater convenience. To insert a drill bit or other accessory, follow the steps listed below.

1. Grasp the rear half of the chuck with one hand and use your other hand to rotate the front half counterclockwise, as shown in Figure 3. Rotate far enough so that the chuck opens sufficiently to accept the desired accessory.
2. Insert the bit or other accessory about 3/4" (19 mm) into the chuck and tighten securely by holding the rear half of the chuck and rotating the front portion in the clockwise direction. When the chuck is nearly tightened, you will hear a clicking sound. After 4–6 clicks, the chuck is securely tightened around the accessory.
- 3 To release the accessory, repeat step 1 listed above.

**⚠ WARNING: Do not attempt to tighten drill bits (or any other accessory) by gripping the front part of the chuck and turning the tool on. Damage to the chuck and personal injury may result.**

### KEYLESS CHUCK REMOVAL (FIG. 4)

Tighten the chuck around the shorter end of a hex key (not supplied) of 1/4" (6 mm) or greater size. Using a soft hammer or piece of wood, strike the longer end in the counterclockwise direction. This will loosen the chuck so that it can be unscrewed by hand.

### KEYLESS CHUCK INSTALLATION (FIG. 5)

Screw the chuck on by hand as far as it will go. Tighten the chuck around the shorter end of a 1/4" (6 mm) or larger hex key (not supplied) strike the longer end in the clockwise direction with a soft hammer.

### Keyed Chuck – D21002

Open the chuck jaws by turning collar by hand and insert the shank of the bit about 3/4" (19 mm) into chuck. Tighten the chuck collar by hand. Place chuck key in each of the three holes, and tighten in clockwise direction. It's important to tighten chuck with all three holes. To release the bit, turn the chuck counterclockwise in just one hole, then loosen the chuck by hand.

### REMOVAL OF KEYED CHUCK (FIG. 6)

Tighten the chuck around the shorter end of a hex key (not supplied) of 1/4" (6 mm) or greater size. Using a soft hammer, strike the key sharply in the counterclockwise direction when viewed from the front of the tool. This will loosen the chuck so that it can be removed by hand.

### KEYED CHUCK INSTALLATION (FIG. 7)

Screw the chuck on by hand as far as it will go. Insert the shorter end of a hex key (not supplied) of 1/4" (6 mm) or greater size and strike it in the clockwise direction with a soft hammer.

## MAINTENANCE

**⚠ WARNING: To reduce the risk of serious personal injury, turn tool off and disconnect tool from power source before making any adjustments or removing/installing attachments or accessories.**

### Cleaning

**⚠ WARNING: Never use solvents or other harsh chemicals for cleaning the non-metallic parts of the tool. These chemicals may weaken the plastic materials used in these parts. Use a cloth dampened only with water and mild soap. Never let any liquid get inside the tool; never immerse any part of the tool into a liquid.**

FIG. 1

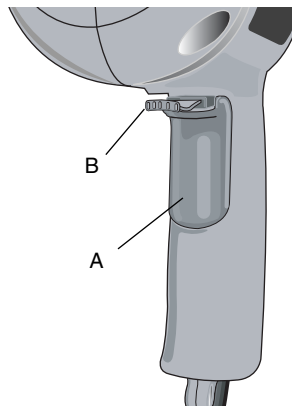

FIG. 2

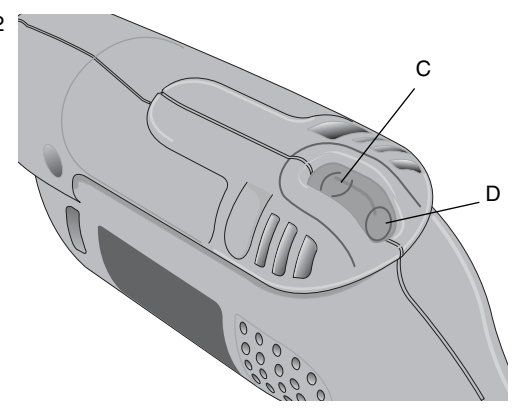

FIG. 3

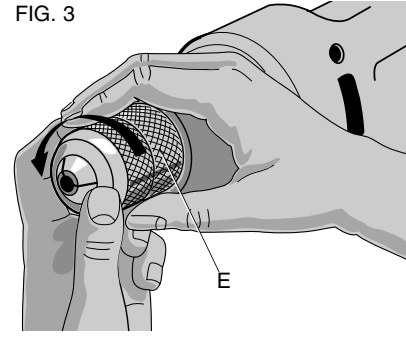

FIG. 4

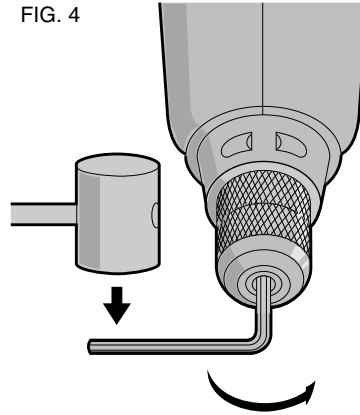

FIG. 5

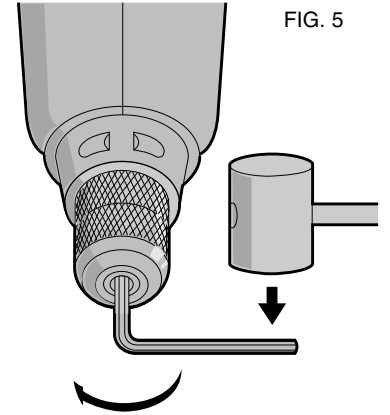

FIG. 6

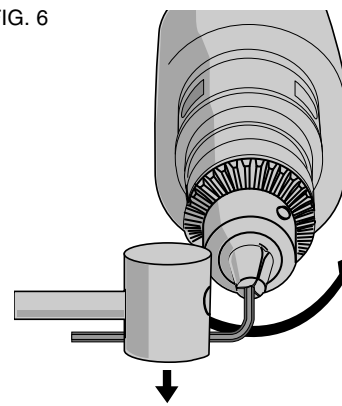
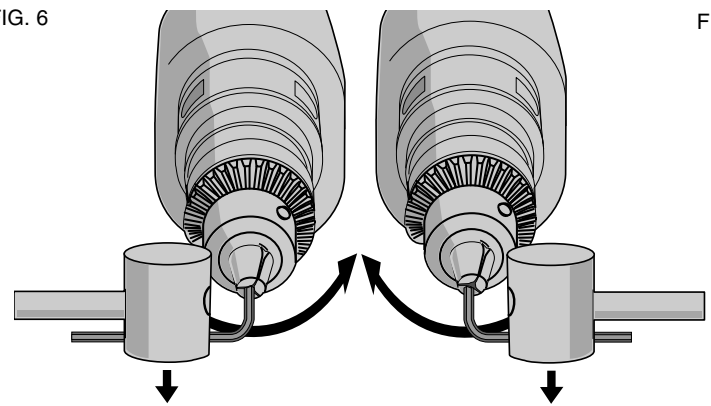

FIG. 7



## Motor Brushes

DeWALT uses an advanced brush system which automatically stops the drill when the brushes wear out. This prevents serious damage to the motor. New brush assemblies are available at authorized DeWALT service centers. Always use identical replacement parts.

## Lubrication

When the tool is taken apart for motor brush replacement a small amount of grease should be added (or redistributed from that remaining in housing) to the gears. The ball bearings used in this tool are lubricated during manufacture and require no lubrication.

## Repairs

To assure product SAFETY and RELIABILITY, repairs, maintenance and adjustments (including brush inspection and replacement) should be performed by a DeWALT factory service center, a DeWALT authorized service center or other qualified service personnel. Always use identical replacement parts.

## Accessories

**⚠ WARNING: Since accessories, other than those offered by DeWALT, have not been tested with this product, use of such accessories with this tool could be hazardous. To reduce the risk of injury, only DeWALT, recommended accessories should be used with this product.**

Recommended accessories for use with your tool are available at extra cost from your local service center.

If you need assistance in locating any accessory, please contact DeWALT Industrial Tool Co., 701 East Joppa Road, Baltimore, MD 21286 or call 1-800-4-DEWALT (1-800-433-9258).

**⚠ CAUTION: To reduce the risk of injury, the following accessories should be used only in sizes up to the maximums shown in the table below.**

MAXIMUM RECOMMENDED CAPACITIES	
Drill capacity	3/8" (10 mm)
R.P.M.	0-2500
Bits, metal drilling	3/8" (10 mm)
Wood, flat boring	1" (25.4 mm)
Bits, masonry drilling	1/2" (12.7 mm)
Hole saws	1-1/8" (28.4 mm)

ACCESSORY MUST BE RATED FOR USE AT SPEED EQUAL TO OR HIGHER THAN NAMEPLATE R.P.M. OF TOOL WITH WHICH IT IS BEING USED.

Wire wheel brushes	4" (101.6 mm) diameter maximum
Wire cup brushes	3" (76.2 mm) diameter maximum
Buffing wheels	3" (76.2 mm) diameter maximum
Rubber backing pads	4-5/8" (117.4 mm) diameter maximum

## Three Year Limited Warranty

DeWALT will repair, without charge, any defects due to faulty materials or workmanship for three years from the date of purchase. This warranty does not cover part failure due to normal wear or tool abuse. For further detail of warranty coverage and warranty repair information, visit [www.dewalt.com](http://www.dewalt.com) or call 1-800-4-DEWALT (1-800-433-9258). This warranty does not apply to accessories or damage caused where repairs have been made or attempted by others. This warranty gives you specific legal rights and you may have other rights which vary in certain states or provinces.

In addition to the warranty, DeWALT tools are covered by our:

### 1 YEAR FREE SERVICE

DeWALT will maintain the tool and replace worn parts caused by normal use, for free, any time during the first year after purchase.

## 90 DAY MONEY BACK GUARANTEE

If you are not completely satisfied with the performance of your DeWALT Power Tool, Laser, or Nailer for any reason, you can return it within 90 days from the date of purchase with a receipt for a full refund – no questions asked.

**LATIN AMERICA:** This warranty does not apply to products sold in Latin America. For products sold in Latin America, see country specific warranty information contained either in the packaging, call the local company or see website for warranty information.

**FREE WARNING LABEL REPLACEMENT:** If your warning labels become illegible or are missing, call 1-800-4-DeWALT for a free replacement.

<b>DXXXXX</b> 3/8" (10mm) VSR DRILL
SER. [REDACTED]
<b>⚠ WARNING</b> TO REDUCE THE RISK OF INJURY, USER MUST READ INSTRUCTION MANUAL. ALWAYS USE PROPER EYE AND RESPIRATORY PROTECTION.
<b>⚠ ADVERTENCIA/AVERTISSEMENT</b>
PARA EL MANEJO SEGURO LEA EL MANUAL DE INSTRUCCIONES. SIEMPRE SE DEBERA LLEVAR LA PROTECCIÓN APROPIADA PARA LA VISTA Y PARA LAS VIAS RESPIRATORIAS. À TITRE PREVENTIF, LIRE LE GUIDE. IL FAUT TOUJOURS PORTER DE L'ÉQUIPEMENT DE PROTECTION OCULAIRE ET RESPIRATOIRE APPROPRIÉ.
DeWALT INDUSTRIAL TOOL CO., BALTIMORE, MD 21286 USA FOR SERVICE INFORMATION, CALL 1-800-4-DeWALT <a href="http://www.DeWALT.com">www.DeWALT.com</a>

<b>DXXXXX</b> 3/8" (10mm) VSR DRILL
SER.
<b>⚠ WARNING</b> AVERTISSEMENT
TO REDUCE THE RISK OF INJURY, USER MUST READ AND UNDERSTAND INSTRUCTION MANUAL. WHEN SERVICING, USE ONLY IDENTICAL REPLACEMENT PARTS. ALWAYS WEAR EYE PROTECTION. À TITRE PREVENTIF, LIRE LE GUIDE D'UTILISATION.
DeWALT INDUSTRIAL TOOL CO., 701 EAST JOPPA ROAD, BALTIMORE, MD 21286 USA FOR SERVICE INFORMATION, CALL 1-800-4-DeWALT <a href="http://www.DeWALT.com">www.DeWALT.com</a>

<b>DWDXXX</b> 3/8" (10mm) VSR DRILL
SER. [REDACTED]
<b>⚠ WARNING</b> TO REDUCE THE RISK OF INJURY, USER MUST READ INSTRUCTION MANUAL. ALWAYS USE PROPER EYE AND RESPIRATORY PROTECTION. <b>⚠ ADVERTENCIA:</b> PARA EL MANEJO SEGURO LEA EL MANUAL DE INSTRUCCIONES; SIEMPRE SE DEBERA LLEVAR LA PROTECCIÓN APROPIADA PARA LA VISTA Y PARA LAS VIAS RESPIRATORIAS. <b>⚠ AVERTISSEMENT:</b> À TITRE PREVENTIF, LIRE LE GUIDE. IL FAUT TOUJOURS PORTER DE L'ÉQUIPEMENT DE PROTECTION OCULAIRE ET RESPIRATOIRE APPROPRIÉ.
DeWALT INDUSTRIAL TOOL CO., BALTIMORE, MD 21286 USA FOR SERVICE INFORMATION, CALL 1-800-4-DeWALT <a href="http://www.DeWALT.com">www.DeWALT.com</a>